

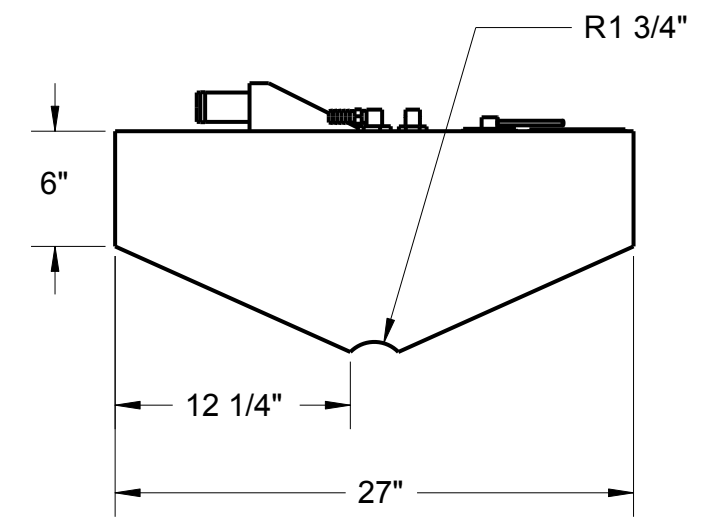

REV.	DATE	REVISIONS DESCRIPTION	REV. BY:

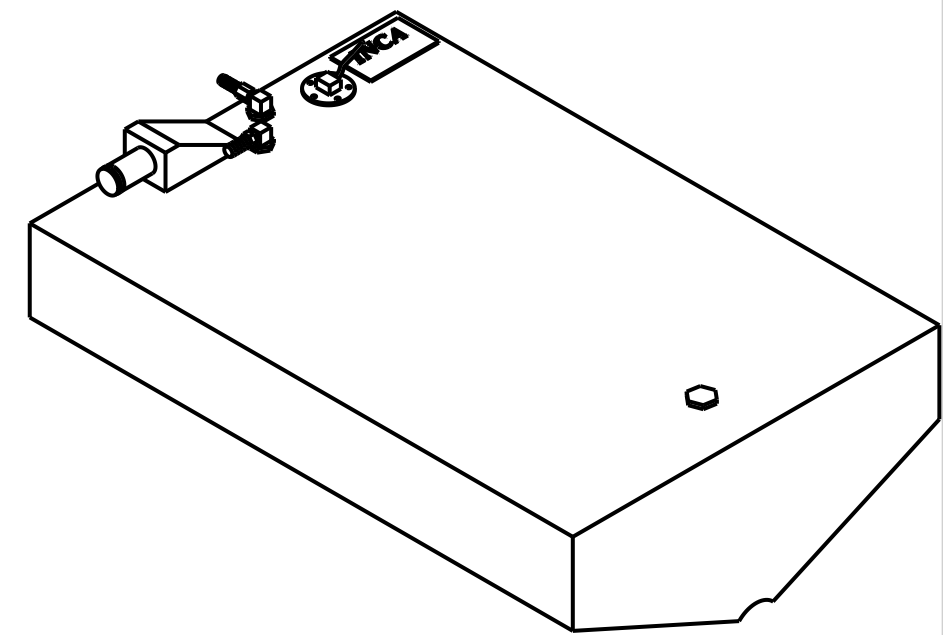
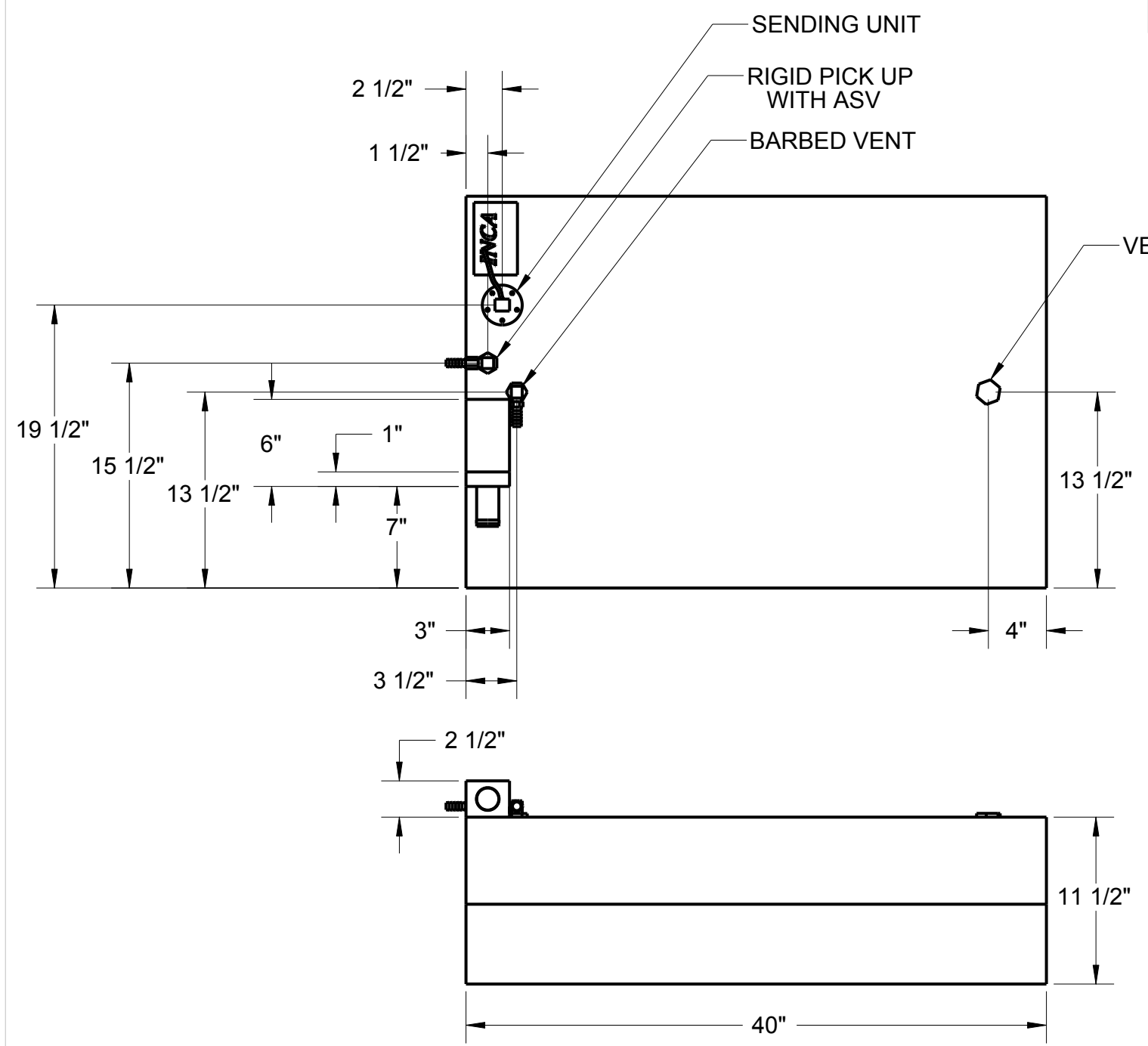

NOTE: PLASTIC FUEL TANKS MUST HAVE SPACE IN TANK COMPARTMENT TO EXPAND 2% FREELY IN ALL DIRECTIONS (LENGTH, WIDTH AND HEIGHT).

- UNLESS NOTED OTHERWISE:
 1) All dimensions in inches
 2) All corner radii to be 3/8"

MAT'L: Polyethylene, Crosslink, Natural
WALL THICKNESS: .225 in. (nominal)

 MOLDED PRODUCTS, INC. <small>INCA MOLDED PRODUCTS, INC. 6400 LOUISIANA AVENUE NASHVILLE, TN 37209 USA (615) 350-7290</small>	FUEL TANK, 42 GAL.		SHEET	1 of 1
			REV. DATE:	
	CHECKED BY:			
	DRAWN BY:	7/6/06	BR	
Copyright by Inca Molded Products, Inc. Nashville, TN 37209 USA		SCALE: 	REVISION: A	FO4222