

REV.	DATE	REVISIONS DESCRIPTION	REV. BY:

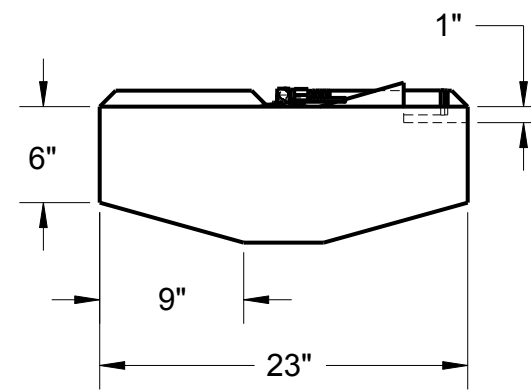
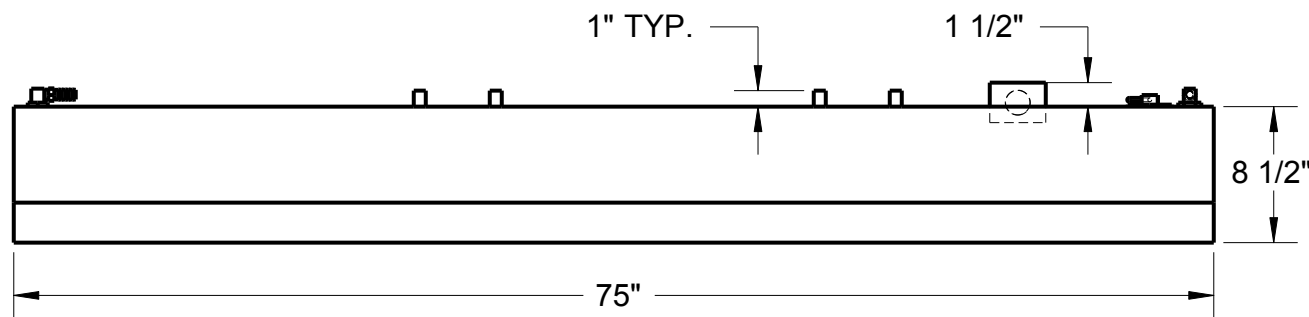
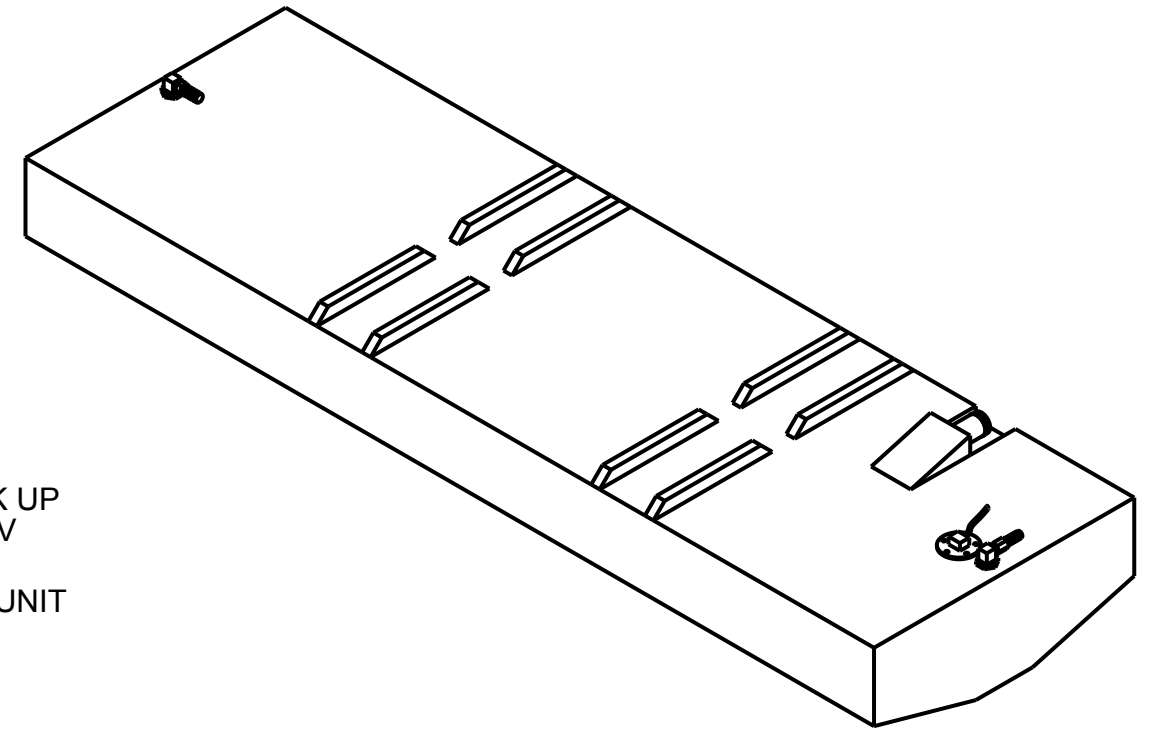
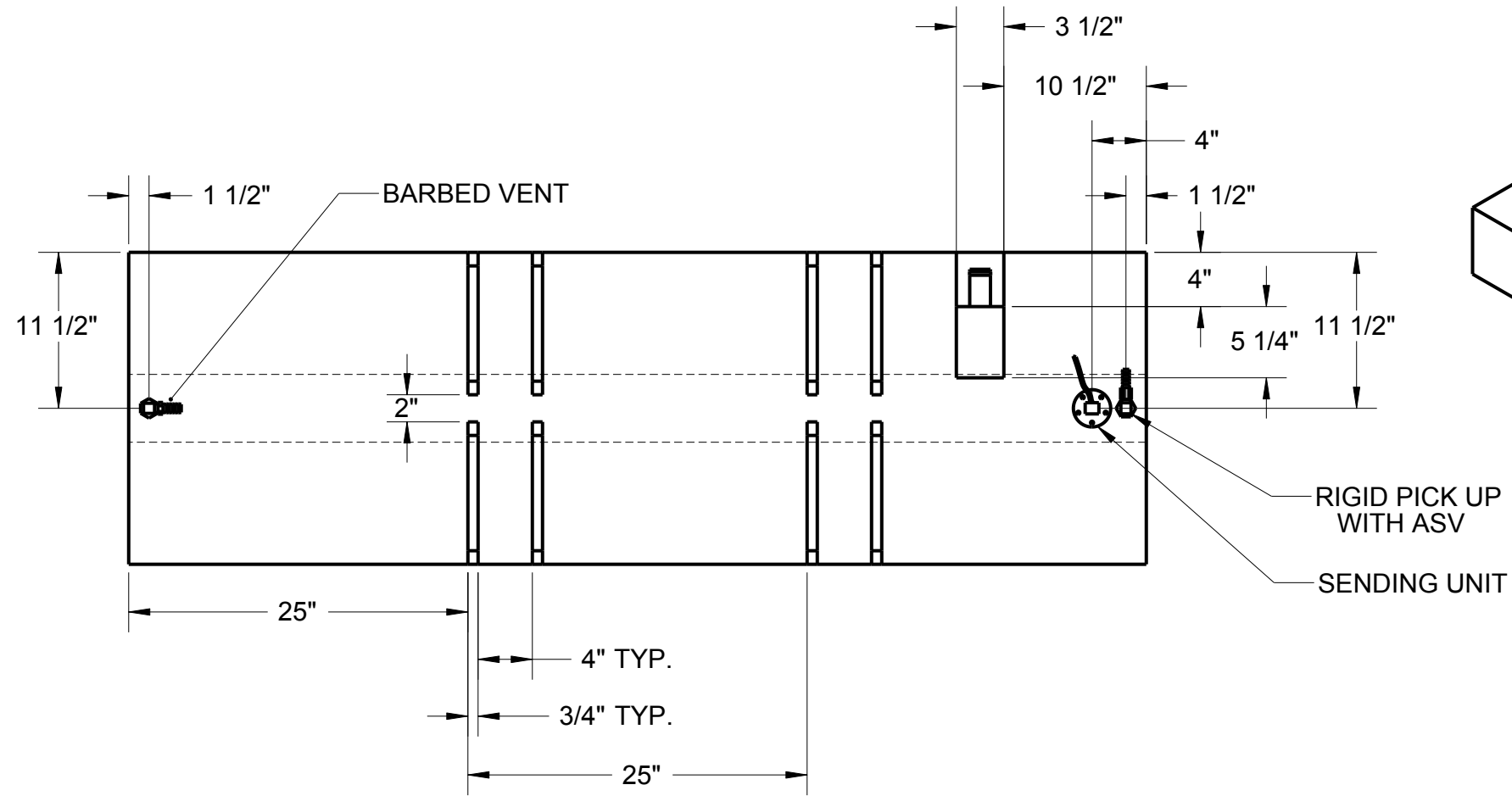

NOTE: PLASTIC FUEL TANKS MUST HAVE SPACE IN TANK COMPARTMENT TO EXPAND 2% FREELY IN ALL DIRECTIONS (LENGTH, WIDTH AND HEIGHT).

UNLESS NOTED OTHERWISE:
 1) All dimensions in inches
 2) All corner radii to be 3/8"

MAT'L: Polyethylene, Crosslink, Natural
WALL THICKNESS: .250 in. (nominal)

<p>INCA MOLDED PRODUCTS, INC. <small>INCA MOLDED PRODUCTS, INC. 6400 LOUISIANA AVENUE NASHVILLE, TN 37209 USA (615) 350-7290</small></p>	<p>FUEL TANK, 53 GAL.</p>		SHEET	1 of 1
			REV. DATE:	
	CHECKED BY:			
	DRAWN BY:	6/21/06	BR	
<p>Copyright by Inca Molded Products, Inc. Nashville, TN 37209 USA</p>		<p>SCALE:</p>	<p>REVISION: A</p>	<p>FO5304</p>