

REV.	DATE	REVISIONS DESCRIPTION	REV. BY:

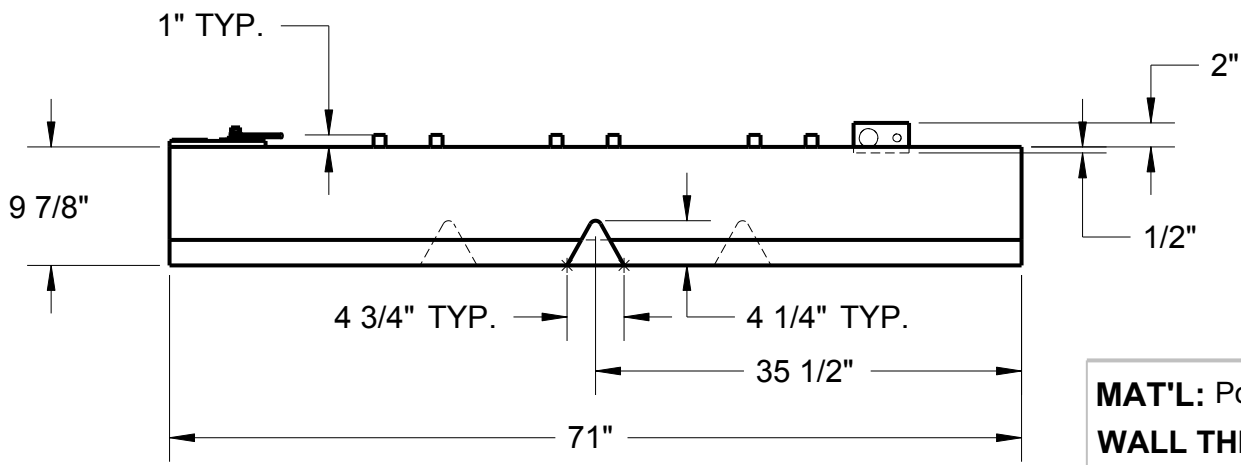
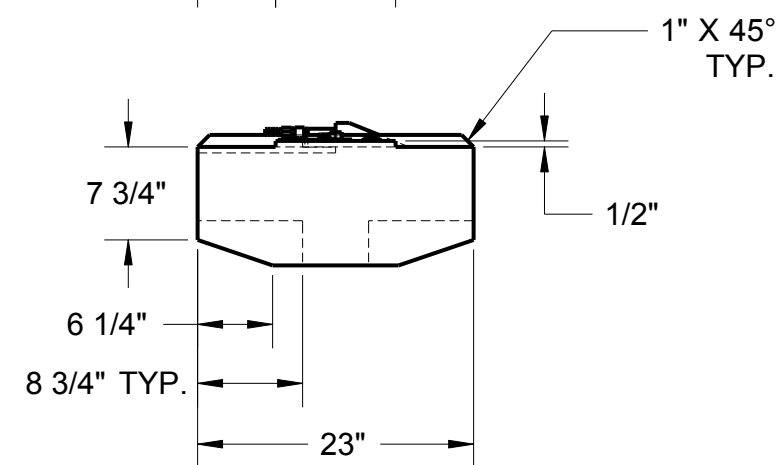
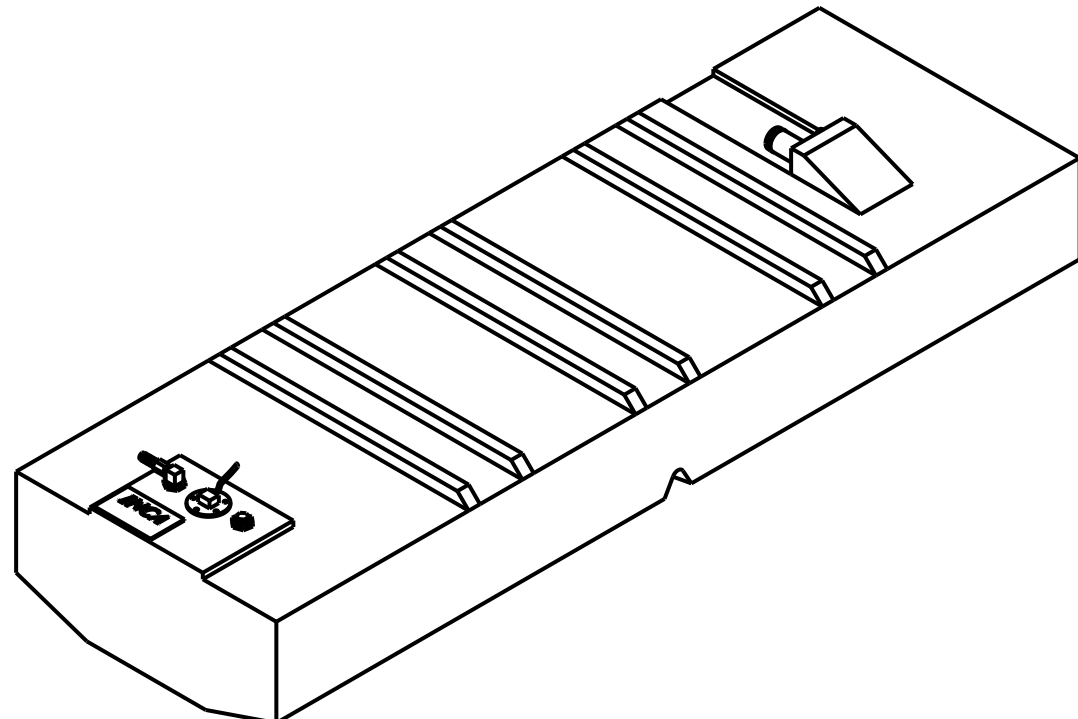
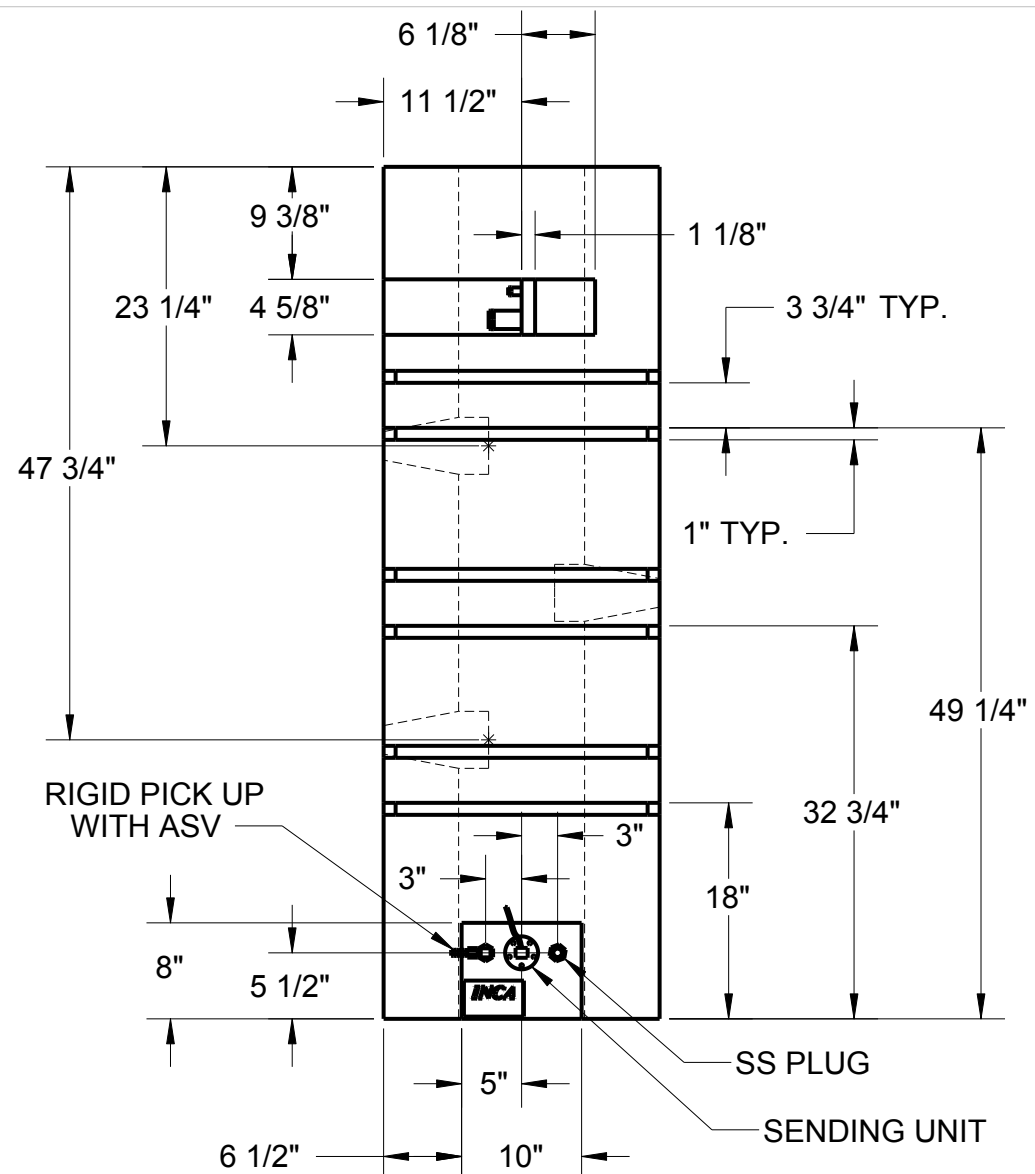

**MAT'L:** Polyethylene, Crosslink, Natural  
**WALL THICKNESS:** .250 in. (nominal)

NOTE: PLASTIC FUEL TANKS MUST HAVE SPACE IN TANK COMPARTMENT TO EXPAND 2% FREELY IN ALL DIRECTIONS (LENGTH, WIDTH AND HEIGHT).

UNLESS NOTED OTHERWISE:  
 1) All dimensions in inches  
 2) All radii to be 3/8"



INCA MOLDED PRODUCTS, INC.  
 6400 LOUISIANA AVENUE  
 NASHVILLE, TN 37209 USA  
 (615) 350-7290

**FUEL TANK, 60 GAL.**

SHEET	1 of 1
REV. DATE:	
CHECKED BY:	
DRAWN BY:	5/31/06 BR

Copyright by Inca Molded Products, Inc.  
 Nashville, TN 37209 USA

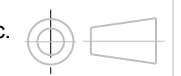

SCALE:

REVISION:  
**A**

**FO6020 S**