

A: SENDING UNIT  
 B: RIGID PICK UP WITH ASV  
 C: BARBED VENT

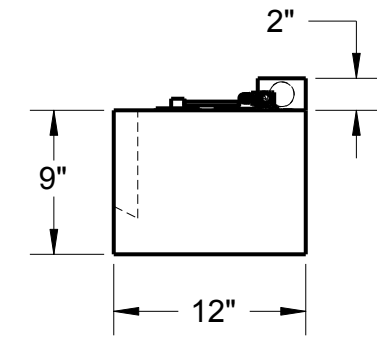

REV.	DATE	REVISIONS DESCRIPTION	REV. BY:

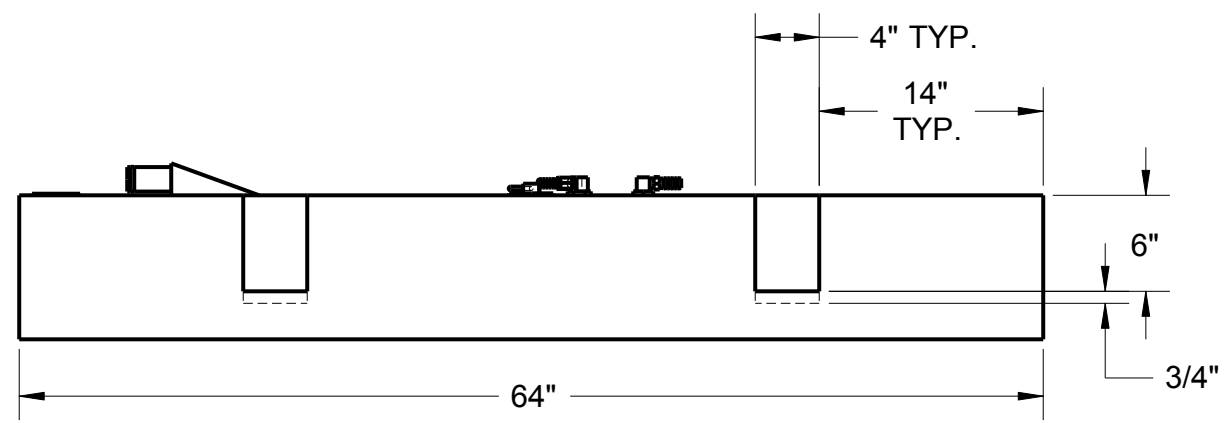
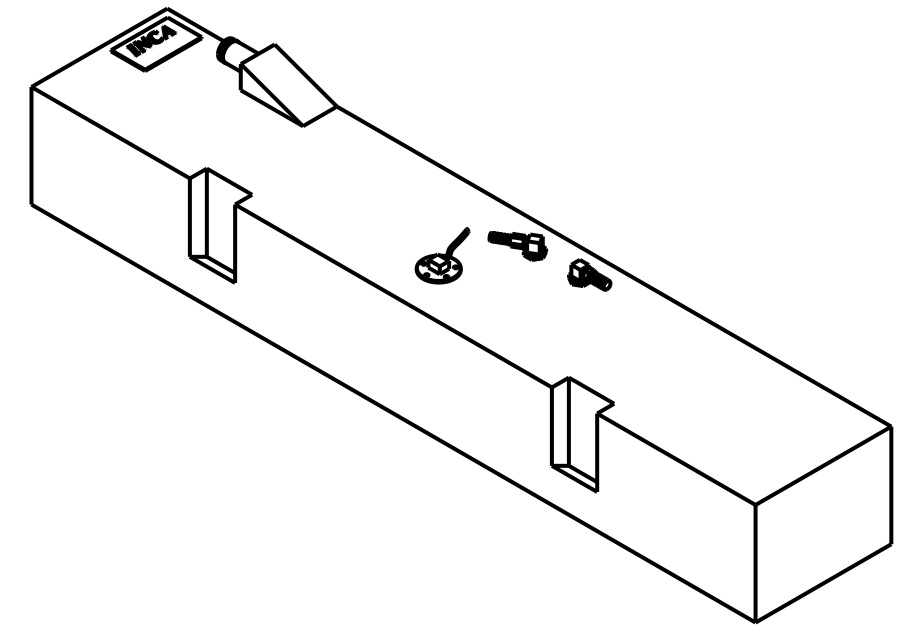
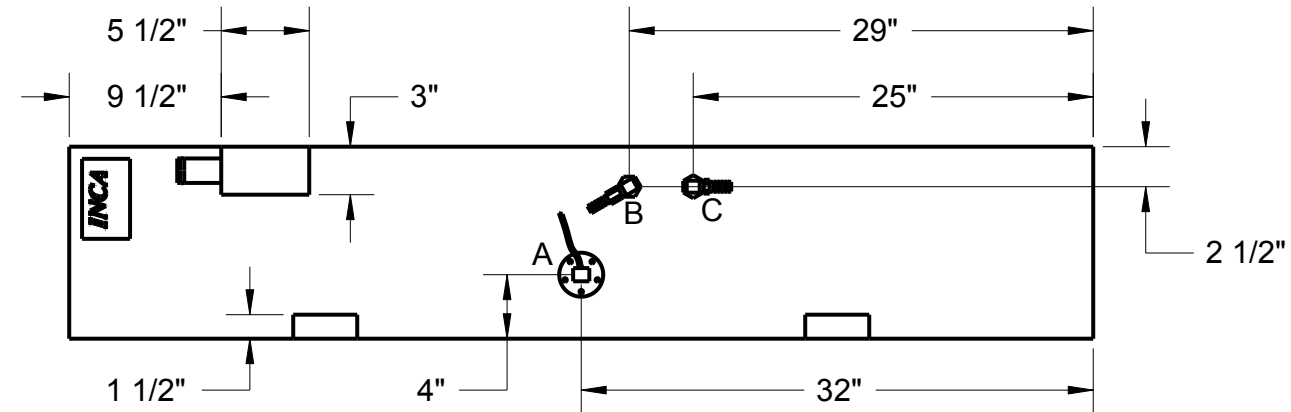

NOTE: PLASTIC FUEL TANKS MUST HAVE SPACE IN TANK COMPARTMENT TO EXPAND 2% FREELY IN ALL DIRECTIONS (LENGTH, WIDTH AND HEIGHT).

UNLESS NOTED OTHERWISE:  
 1) All dimensions in inches  
 2) All corner radii to be 3/8"

**MAT'L:** Polyethylene, Crosslink, Natural  
**WALL THICKNESS:** .210 in. (nominal)

 <b>MOLDED PRODUCTS, INC.</b> <small>INCA MOLDED PRODUCTS, INC.          6400 LOUISIANA AVENUE          NASHVILLE, TN 37209 USA          (615) 350-7290</small>	<b>FUEL TANK, 27 GAL.</b>		SHEET	1 of 1
			REV. DATE:	
	CHECKED BY:			
	DRAWN BY:	6/15/06	BR	
<small>Copyright by Inca Molded Products, Inc.          Nashville, TN 37209 USA</small>		 SCALE:	REVISION: <b>A</b>	<b>FO2718</b>